



SaniForce® 2.0

Air-Operated Double Diaphragm Pumps for food, beverage, personal care, cosmetics, & pharmaceutical applications



protect your **PROCESS**

Portable, easy-to-clean, quick knockdown design

- > Durable design for rigorous, continuous use
- > Maximum flow rates up to 250 gpm (946 lpm)
- > Featuring Graco's durable, lube-free, non-stick air valve
- > Quick knockdown for easy cleaning, sanitizing, and draining
- > All fluid contact materials are FDA-Compliant and meet CFR Title 21

INGREDIENTS TRANSPORT

SaniForce Solutions

Improved cleanability, safety, and ease of use

protect your **PROCESS**

FG-Series (Food Grade)



SaniForce FG 515	SaniForce FG 1040	SaniForce FG 1590	SaniForce FG 2150
15 gpm (57 lpm)	40 gpm (151 lpm)	90 gpm (341 lpm)	150 gpm (568 lpm)
Up to 5,000 cps	Up to 10,000 cps	Up to 15,000 cps	Up to 25,000 cps
3/32 in (2.38 mm)	1/8 in (3.2 mm)	3.16 in (4.8 mm)	1/4 in (6.4 mm)

HS-Series (High Sanitation)



SaniForce HS 1040	SaniForce HS 1590	SaniForce HS 2150	SaniForce HS 3250
40 gpm (151 lpm)	100 gpm (379 lpm)	150 gpm (568 lpm)	250 gpm (946 lpm)
Up to 10,000 cps	Up to 15,000 cps	Up to 25,000 cps	Up to 25,000 cps
1/8 in (3.2 mm)	3/16 in (4.8 mm)	1/4 in (6.4 mm)	3/4 in (19 mm)

Typical Materials



LP-Series (Large Particle)



SaniForce 1590	SaniForce 3150	SaniForce 4150	SaniForce 3150	SaniForce 4150
80 gpm (303 lpm)	130 gpm (492 lpm)	90 gpm (341 lpm)	130 gpm (492 lpm)	90 gpm (341 lpm)
Up to 15,000 cps	Up to 15,000 cps	Up to 15,000 cps	Up to 15,000 cps	Up to 15,000 cps
1.25 in (31.8 mm)	2.6 in (66 mm)	3.8 in (96.5 mm)	2.6 in (66 mm)	3.8 in (96.5 mm)

3A-Series (3-A Approved)



SaniForce 3A 1590	SaniForce 3A 2150	SaniForce 3A 3250
100 gpm (379 lpm)	150 gpm (568 lpm)	250 gpm (946 lpm)
Up to 15,000 cps	Up to 25,000 cps	Up to 25,000 cps
3/16 in (4.8 mm)	1/4 in (6.4 mm)	3/4 in (19 mm)

PH-Series (Pharmaceutical)



SaniForce PH 1040	SaniForce PH 1590	SaniForce PH 2150	SaniForce PH 3250
40 gpm (151 lpm)	100 gpm (379 lpm)	150 gpm (568 lpm)	250 gpm (946 lpm)
Up to 10,000 cps	Up to 15,000 cps	Up to 25,000 cps	Up to 25,000 cps
1/8 in (3.2 mm)	3/16 in (4.8 mm)	1/4 in (6.4 mm)	3/4 in (19 mm)



SaniForce® Diaphragms & Air Valves

All SaniForce diaphragm pumps are available with our signature overmolded diaphragms and externally serviceable air valves for cleaner and smoother operations.

With PTFE on the fluid side and EPDM on the air side, SaniForce overmolded diaphragm pumps are one of the easiest to clean and longest lasting in the market.

Prevent bacteria growth with the Graco overmolded diaphragm.

- > Improve wear and diaphragm life with no exposed diaphragm plate on the fluid side
- > Longer diaphragm life in applications that still require PTFE
- > Molded in fluid plate removes areas for food to hide – easier cleaning

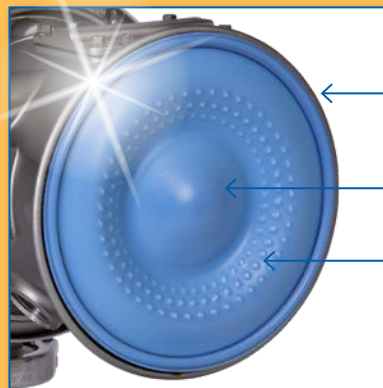

EDPM backer

No fluid side plate

PTFE overmolded fluid side diaphragm

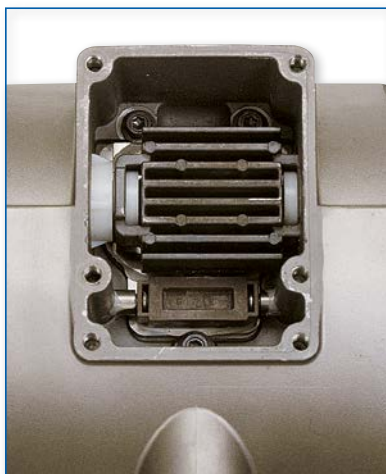

Increase uptime with durable, externally serviceable air valve.

With fewer moving parts and external serviceability, SaniForce air valves offers leading efficiency and less downtime. The-lube free, non-stick design is one of most hygienic options on the market.

- Increase durability and reduce repair time with fewer moving parts
- Externally serviceable (pilot and air valve) for quick, inexpensive repairs
- Three-way pilot valve for non-stick operation
- Lube-free for increased sanitation

SaniForce® Rotatable Stand

Many SaniForce diaphragm pumps are available with our convenient rotatable stand.

With the need for quick draining and easy servicing many SaniForce diaphragm pumps offer the rotatable stand solution.

Rotatable stand for quick draining and easy servicing

- Quick-release key
- Decrease downtime
- 360° rotation
- Easy cleaning, draining and service

Available on the following pumps:

- SaniForce HS-Series
- SaniForce LP-Series
- SaniForce 3A-Series
- SaniForce PH-Series

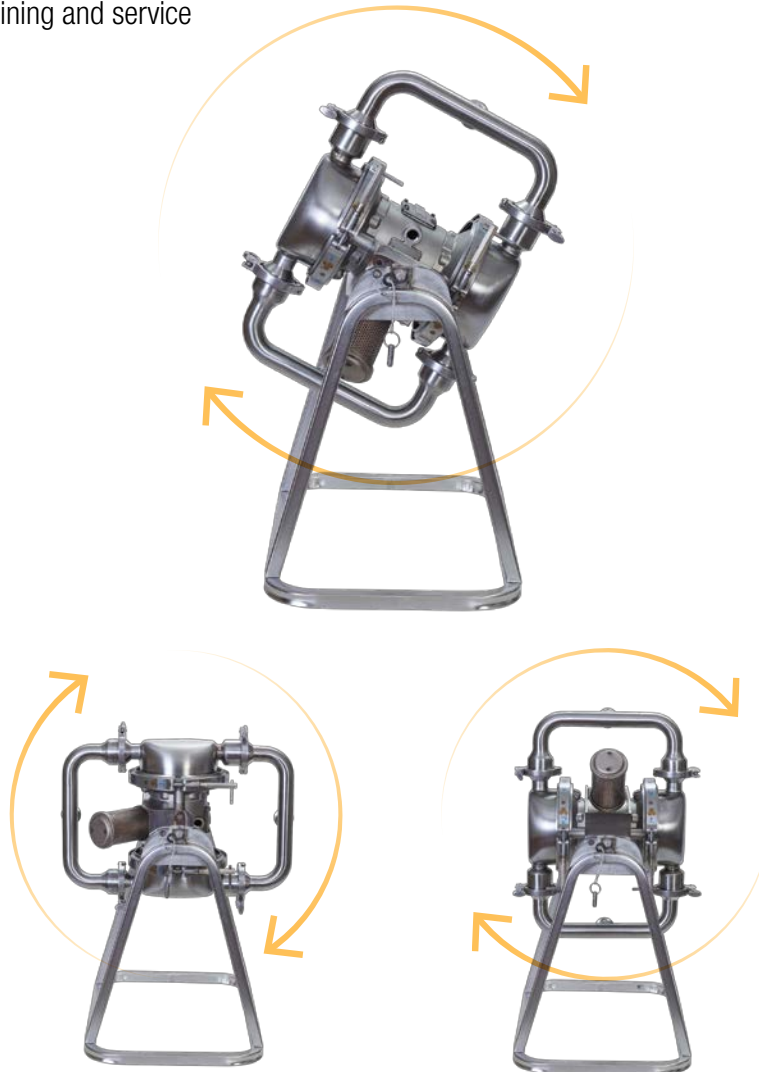

SaniForce® FG-Series Diaphragm Pumps

Increase durability and reduce repair time with fewer moving parts.

- Externally serviceable air valve for quick, inexpensive repairs
- Designed for rigorous, continuous use with quick knockdown design for easy cleanability and sanitation
- Ideal for applications requiring high flow rates and portability

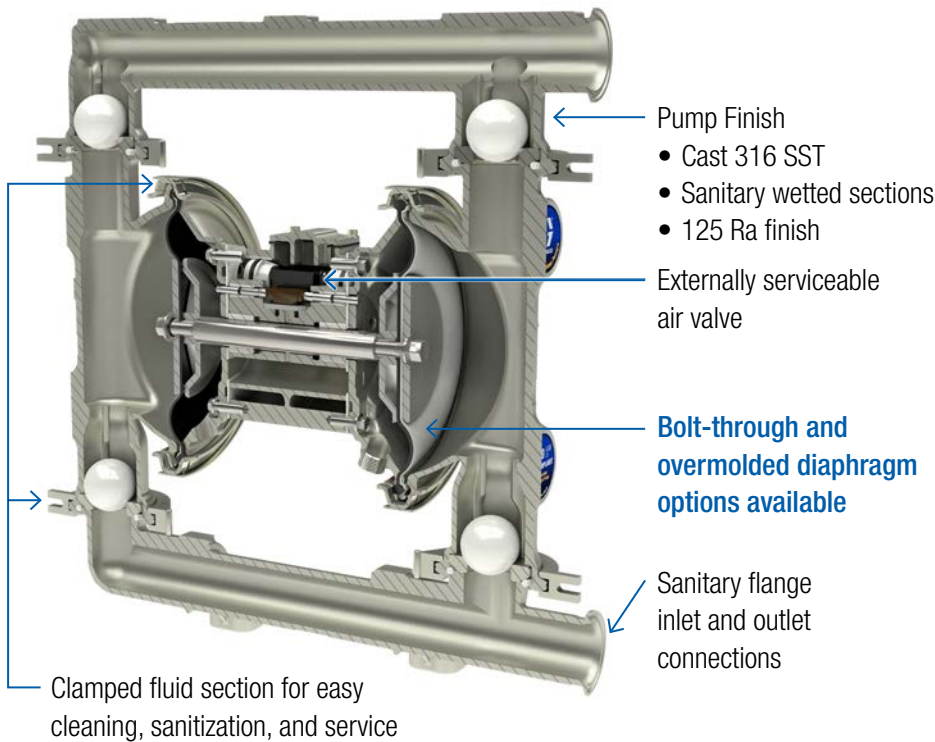

Fluid contact areas are all FDA-compliant and meet CFR Title 21



	SaniForce 515	SaniForce 1040	SaniForce 1590	SaniForce 2150
Fluid Connection	1 in	1.5 in	2 in	2.5 in
Maximum Viscosity	Up to 5,000 cps	Up to 10,000 cps	Up to 15,000 cps	Up to 25,000 cps

Common Materials	Salad dressings	Edible oils
	Condiments	Snack food flavorings
	Sauces	Light lotions and creams
	Juices and flavored drinks	Beer, wine & more

SaniForce® HS-Series Diaphragm Pumps

Easy to clean and sanitize pump for high care applications.

- Fewest gaskets and clamps for improved flushing
- Fewer areas for food and bacteria to hide for increased sanitation and easier cleaning
- Three-way pilot valve for non-stick operation
- Externally serviceable air valve for quick, inexpensive repairs

Patented, durable, lube-free air valve

Sanitary flange and DIN connections

32 Ra formed/welded stainless steel with sanitary finish

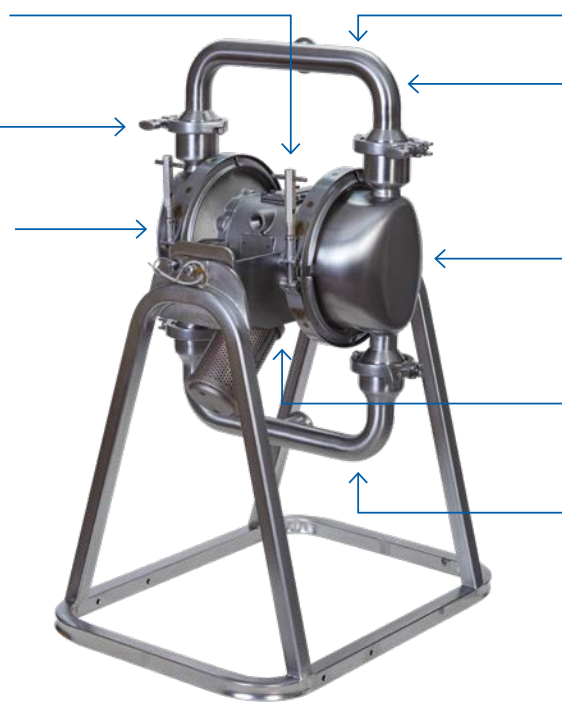

316 L SST Construction

Single piece manifold reduces clamps and areas for food and bacteria to hide

Overmolded and bolt in diaphragm options are available

Leak detector available on HS models

Optimized fluid path improves cleanability and sanitization

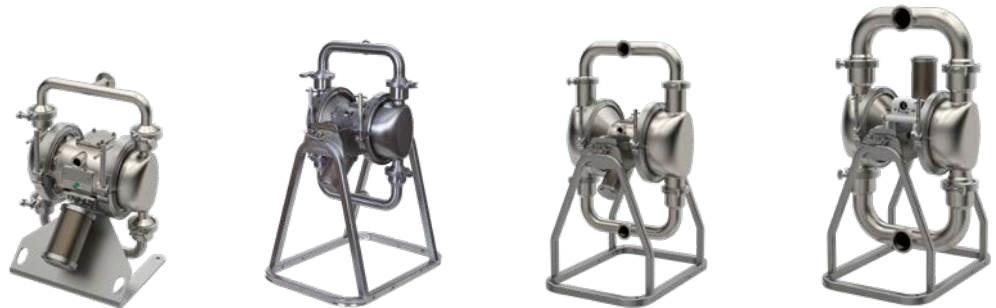

	SaniForce HS 1040	SaniForce HS 1590	SaniForce HS 2150	SaniForce HS 3250
Fluid Connection	1 in	1.5 in	2 in	3 in
Maximum Viscosity	Up to 10,000 cps	Up to 15,000 cps	Up to 25,000 cps	Up to 25,000 cps

Common Materials	Personal care	Lotions and creams
	Cosmetics	Variiegates
	High care food	Sauces and dressings

SaniForce® LP-Series Diaphragm Pumps

Built to handle solids up to 3.8 inches in diameter

- Easy to clean sanitary flange connections for a quick knockdown design and minimal downtime
- Durable pump construction handles particulates and abrasives in material without damage to pump
- 3 and 4 inch sizes available in both air and electric operated models

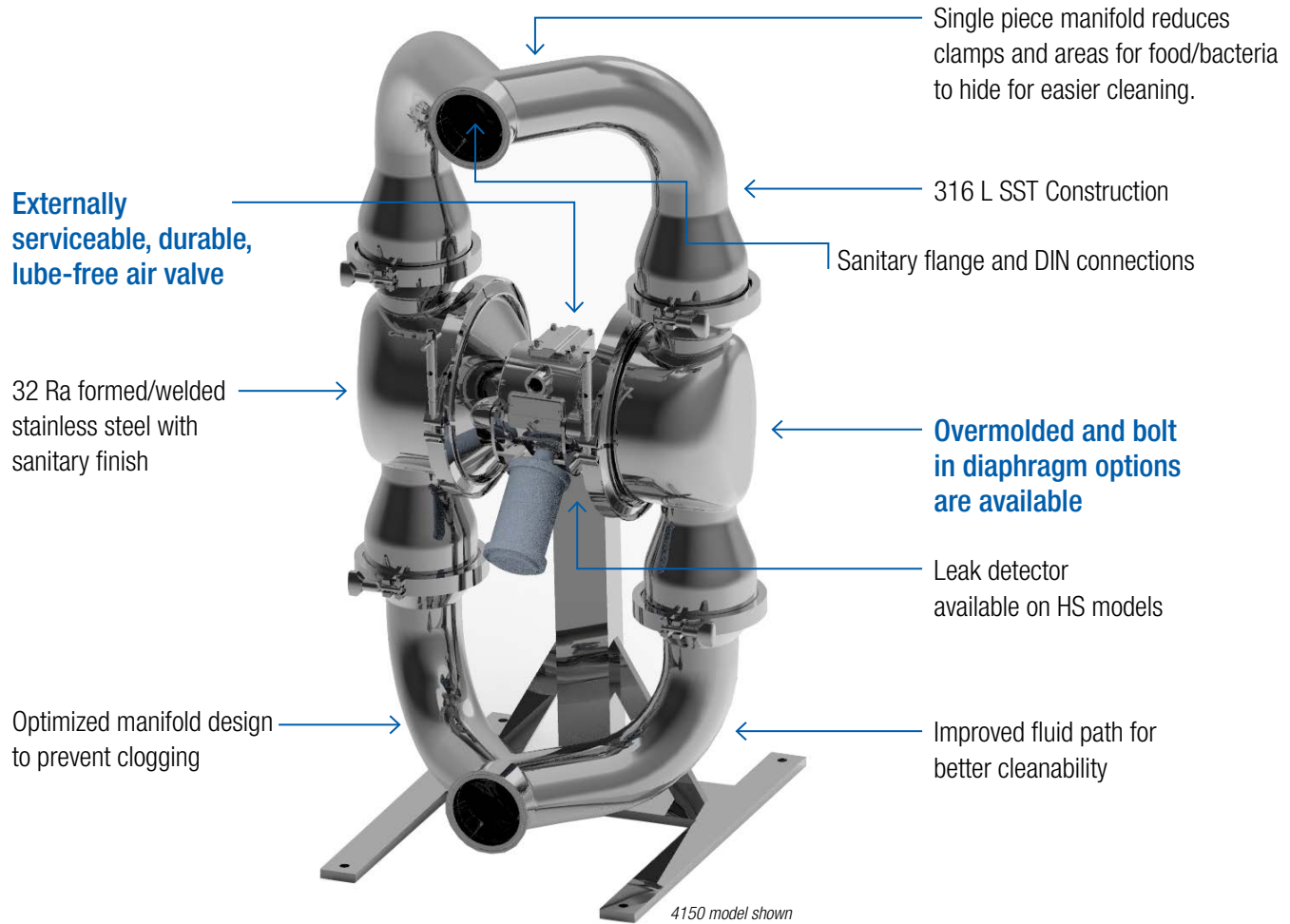

Flapper Check

Handles solids up to 3.8 inches (97 mm) without crushing or damaging material



Large Particle Pump Sizes



	SaniForce 1590	SaniForce 3150	SaniForce 4150
Maximum Particle Size	1.2 in max pumpable solids (30 mm)	2.6 in max pumpable solids (66 mm)	3.8 in max pumpable solids (97 mm)
Maximum Flow	80 gpm (303 lpm)	130 gpm (492 lpm)	90 gpm (341 lpm)
Maximum Viscosity	Up to 15,000 cps	Up to 15,000 cps	Up to 15,000 cps
Fluid Connection	1.5 in sanitary flange	3 in sanitary flange	4 in sanitary flange



	SaniForce 3150*	SaniForce 4150**
Maximum Particle Size	2.6 in max pumpable solids (66 mm)	3.8 in max pumpable solids (97 mm)
Maximum Flow	130 gpm (492 lpm)	90 gpm (341 lpm)
Maximum Viscosity	Up to 15,000 cps	Up to 15,000 cps
Fluid Connection	3 in sanitary flange	4 in sanitary flange

*Shown with optional single inlet & outlet manifolds

**Available with single inlet/outlet manifolds

Common Materials

Meat & Poultry

Fruit filling materials

Ice cream varigates

SaniForce® 3A-Series Diaphragm Pumps

3A Certified diaphragm pump for handling dairy safely and effectively.

- Increase durability and reduce repair time with fewer moving parts
- Three-way pilot valve for non-stick operation
- Externally serviceable for quick, inexpensive repairs
- Leak sensors installed with optional control box



Patented, durable, lube-free air valve

32 Ra formed/welded stainless steel with sanitary finish

Rotatable stand for quick draining and easy servicing

Single piece manifold reduces clamps and areas for food/bacteria to hide for easier cleaning

Sanitary flange and DIN connections

Overmolded and bolt in diaphragm options are available

Leak detector installed on 3A models

***Leak detector box available**



	SaniForce 3A 1590	SaniForce 3A 2150	SaniForce 3A 3250
Maximum Viscosity	Up to 15,000 cps	Up to 25,000 cps	Up to 25,000 cps
Fluid Connection	1.5 in sanitary flange	2 in sanitary flange	3 in sanitary flange

Common Materials	Dairy	Ice cream ingredients
	Yogurt	
	Cottage cheese	

SaniForce® PH-Series Diaphragm Pumps

Pharmaceutical grade diaphragm pump.

- Increase durability and reduce repair time with fewer moving parts
- Three-way pilot valve for non-stick operation
- Externally serviceable for quick, inexpensive repairs
- 20 Ra electropolished finish



Patented, durable, lube-free air valve

20 Ra formed/welded stainless steel with electropolished sanitary finish

Rotatable stand for quick draining and easy servicing

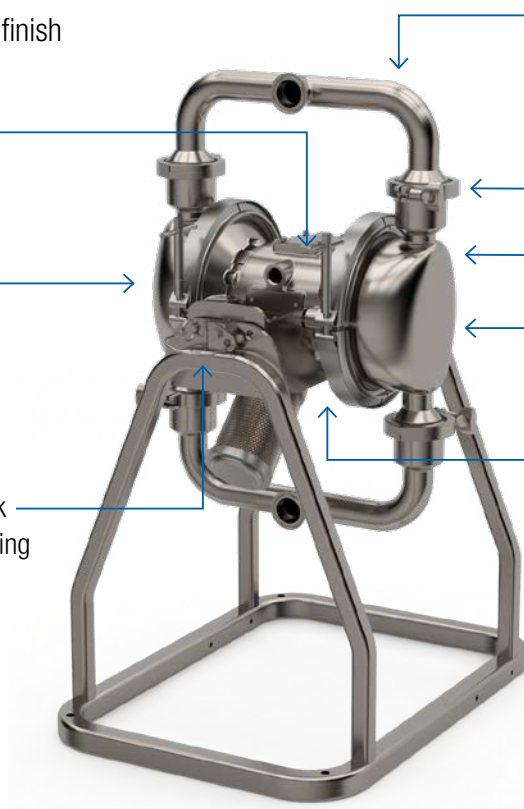

Single piece manifold reduces clamps and areas for food and bacteria to hide for easier cleaning

Sanitary flange and DIN connections

316L SST wetted sections

Overmolded and bolt in diaphragm options are available

Leak detector available for Pharma models 1590, 2150, and 3250



	SaniForce PH 1040	SaniForce PH 1590	SaniForce PH 2150	SaniForce PH 3250
Fluid Connection	Up to 10,000 cps	Up to 15,000 cps	Up to 25,000 cps	Up to 25,000 cps
Maximum Viscosity	1 in sanitary flange	1 in sanitary flange	2 in sanitary flange	3 in sanitary flange

Common Materials	Medical creams & lotions	Bio pharmaceuticals
	Organic reagent	Alcohol
	Blood products	Solvent

APPLICATIONS

Application Overview

Transfer options available for low to high viscosity materials from food to personal care to pharmaceuticals.

- > **FOODS:** Low to high viscosity ingredients including juices & flavored drinks, salad dressings & condiments, edible oils, snack food flavorings, frostings, beer & wine, caramels & chocolate syrups, jams & fruit fillings, tomato paste, peanut butter, and more



- > **DAIRY:** Yogurt, cottage cheese, ice cream ingredients



- > **PERSONAL CARE:** Lotions & creams, cosmetics, and high care food



- > **PHARMA:** Medical creams & lotions, organic reagent, blood products, bio pharmaceuticals, alcohol and solvent transfer



protect your **PROCESS**

All written and visual data contained in this document are based on the latest product information available at the time of publication. Graco reserves the right to make changes at any time without notice.

Call today for product information or to request a demonstration.
800.328.0211 or visit us at www.graco.com/sanitary

©2019 Graco Inc. Form No. 320462 Rev. 1 04/19 Printed in the U.S.A.
All other brand names or marks are used for identification purposes and are trademarks of their respective owners.

